



VOKSLYTE™

Merging the art of metal and the science of light

TANGENT-Down™ Custom Downlight Contours



Luminance: Tangent-Down Surface Mounted
Project: Comcast Headquarters • Philadelphia, PA
Lighting Design: Tillotson Design Associates
Architect: Gensler



Tangent Down™ custom lighting contours from VoksLyte™

Our stunning sculptural luminaires can be furnished in almost any shape or configuration that the designer desires: curves of any radius, rectilinear shapes, curvilinear shapes, free-form shapes, ellipses & ellipsoids, curvatures in plan and in elevation...The list goes on. VoksLyte™ has no standard geometries, as we manufacture the exact shapes for which the architecture, and the lighting design requires.

Light engines are high efficiency, high CRI (90+) LEDs, and can be furnished in Kelvin temperatures from 2700°K to 4000°K. RGBW and variable White are also available.

TANGENT-Down™ Custom Downlight Contours

- High quality heavy aluminum construction
- Highly light-transmissive translucent acrylic lens
- Available as a hanging pendant, recessed mounted or surface mounted
- An infinite variety of circular, elliptical, rectilinear or curvilinear shapes
- Sections join together seamlessly with no light leakage
- Manufactured to exacting dimensional tolerances
- Long-life tightly binned Luminus LEDs (90+ CRI)
- Dimmable 0-10 constant-current drivers are integral to the luminaire
- Constant-voltage remote drivers are dimmable via 0-10 control
- Can be painted in almost any commercially available powder coat color
- Contractor-friendly replaceable LED boards and drivers
- Available in RGBW (DMX control) and variable white (please contact the factory)
- UL dry and damp location listed
- **Chicago Plenum approved** for recessed mounting (**CVMO** driver version only)
- **Made in the USA**



Dimensional Design Information

The tangent system is composed of multiple segments which seamlessly join together. A multi-segment luminaire has no maximum length.

Typical segment length:	60 to 72 inches
Minimum continuous radius:	12-inch outside radius
Minimum corner radius:	6-inch outside radius
Maximum radius:	Infinite

Electrical Information

Input voltage:	120-277 (integral 0-10 volt dimmable drivers)
	120-277 (remotely located 0-10 or DMX dimmable drivers)
Standard-Output Watts (constant current, integral driver):	6 watts per foot
High-Output Watts (constant current, integral driver):	9 watts per foot
Mid-Output Remote driver Watts (constant voltage):	8 watts per foot
DMX controlled RGBW (constant voltage, remote driver):	6 watts per foot

Dimming Information

Integral 0-10 constant current drivers will dim to 5% or less
 Remote 0-10 constant voltage drivers and DMX drivers will dim to 1%

White LED Kelvin Temperatures

Please Note: These values are delivered lumens and delivered efficacies (lumens and efficacies measured directly at the LED surface are far higher).

CC= Constant Current and CV= Constant Voltage

Cat. No.	Description	CCSO		CCHO		CVMO	
		Integral CC, Standard-Output		Integral CC Driver, High-Output		Remote CV Driver, Mid-Output	
		Lumens/ft.	Efficacy	Lumens/ft.	Efficacy	Lumens/ft.	Efficacy
27K	Incandescent 2700°K	357	64 Lumens/watt	552	65 Lumens/watt	430	60 Lumens/watt
30K	Warm White 3000°K	376	66 Lumens/watt	581	66 Lumens/watt	453	62 Lumens/watt
35K	Soft White 3500°K	395	71 Lumens/watt	610	72 Lumens/watt	476	66 Lumens/watt
40K	Cool White 4000°K	414	74 Lumens/watt	639	75 Lumens/watt	498	69 Lumens/watt

A word about how to order...

Tangent is essentially a very simple product that can be made to do very complex things. We however, feel strongly that the ordering process shouldn't be complex. We don't have complicated families of fixed curvatures from which to choose, which makes the specifier's job infinitely easier. Just draw your shape(s) on the reflected ceiling plan, create your catalog number, and let VoksLyte do the rest.

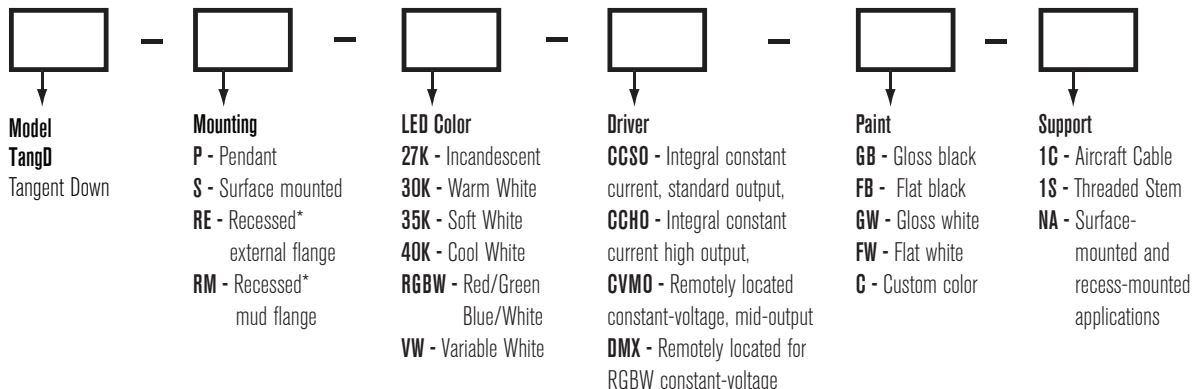

*Recessed models (either mud flange or external flange) may only be paired with CCSO or CVMO drivers. Recessed Chicago Plenum applications can utilize CVMO drivers only.

Specifications are subject to change at manufacturer's discretion.



VOKSLYTE™

Merging the art of metal and the science of light

TANGENT-Down™ Custom Downlight Contours

Mounting Options

Surface Mounted

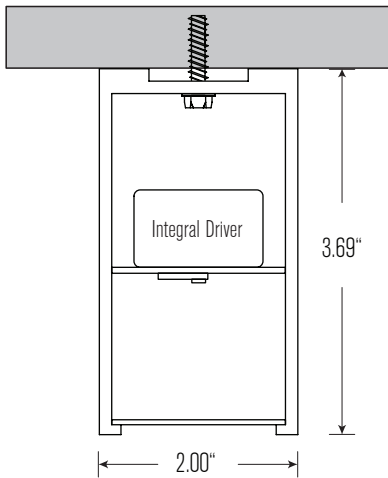

Pendant Mounted

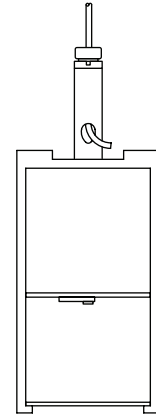
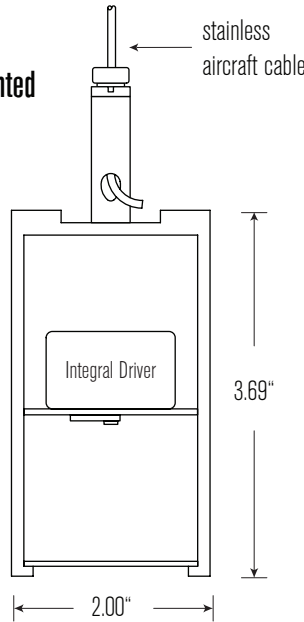

Please note: Profiles are shown with the constant current integral driver option. Luminaires using the constant-voltage remote-driver or DMX option will be identical in every dimension, but will not contain an integral driver.

Recess Mounted with External Flange

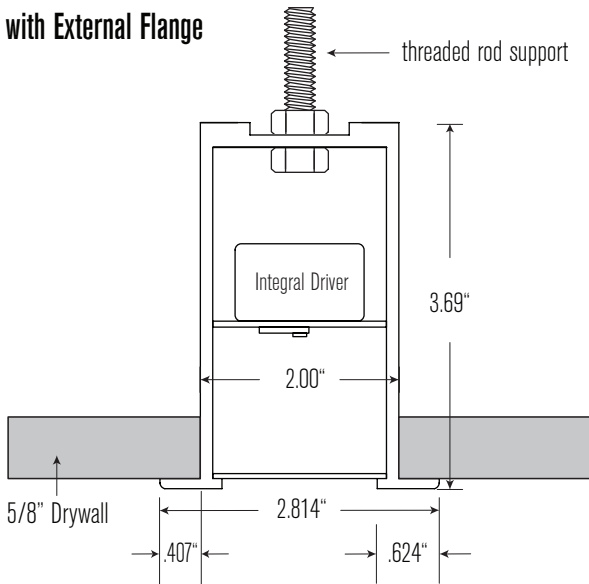

Recess Mounted with Mud Flange

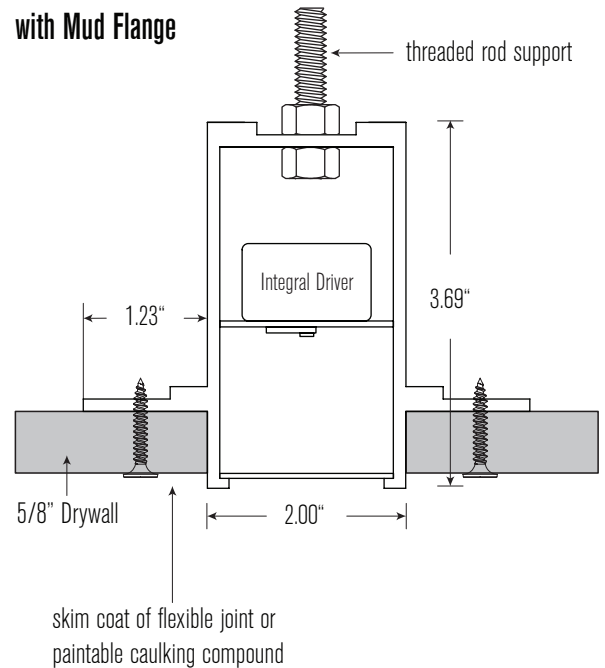

TANGENT-Down™ Custom Downlight Contours

IES files and full photometric reports are available for download on the VoksLyte website: www.VoksLyte.com/photometry/

Photometric Information

Use the following multiplication factors for these color temperatures:

- 27K** Incandescent 2700°K: multiply by 0.95
- 30K** Warm White 3000°K: multiply by 1
- 35K** Soft White 3500°K: multiply by 1.05
- 40K** Cool White 4000°K: multiply by 1.1

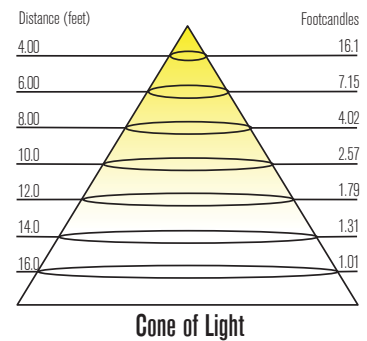
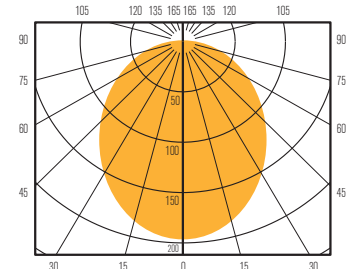
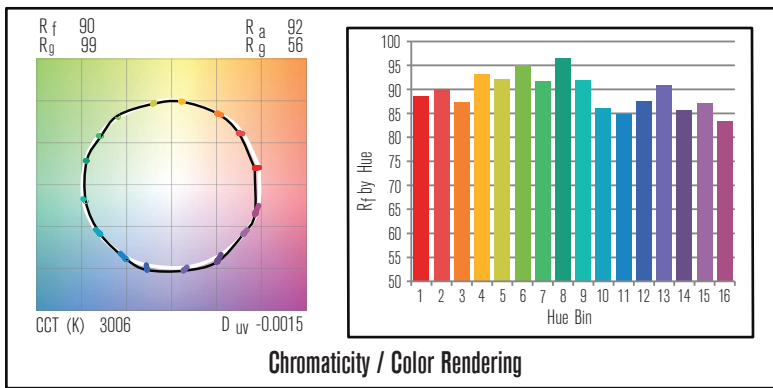

Capabilities & Design Guidelines

As a custom manufacturer using standardized profiles, VoksLyte is able to create almost any shape imaginable. Tangent Down can be provided in radii as small as 6-inches (outside radius) or as large as 1000-feet...and beyond. We can seamlessly intersect fixture shapes. We can provide custom miters on any corner or end piece, and we can curve our luminaires in elevation as well as curving them in plan. We however, cannot curve Tangent Down in both plan and elevation at the same time. If your design idea is not covered within the confines of our catalog or website, please feel free to contact the factory for assistance...we are always willing to assist you in making something new or novel.

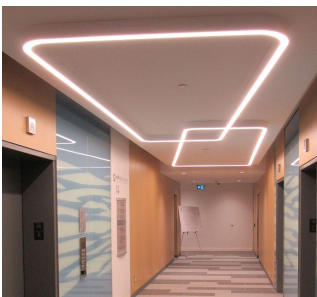

Tangent Down with 6-inch outer radii and seamless intersections

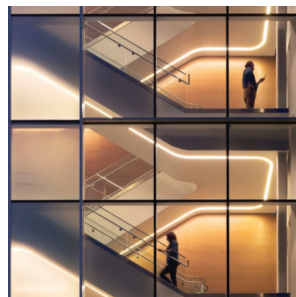

Tangent Down with curvatures in elevation, transitioning to curvatures in plan



Tangent Down with custom curvatures in plan, terminating in custom mitered ends, which compliment the intersecting radii

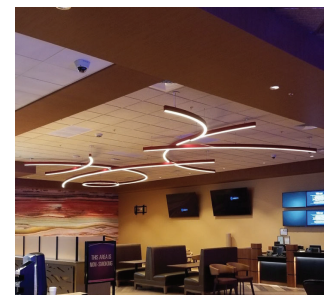

Tangent Down with custom curvatures in plan and gloss red powdercoat finish

Specifications

Luminaire - Extruded aluminum in baked powder coated finish as specified. Fabricated to curvatures and/or lengths specified.

LED Light Engine - Luminus™ 2700°K, 3000°K, 3500°K, 4000°K or LumiLeds™ RGBW

Integral Driver - Constant current class 2 UL-8750 0-10 dimmable. Sound rated A - Complies with FCC 47 CFR Part 15.

Remote Driver - Constant voltage class 2 UL-Listed. 0-10 and DMX dimmable, Sound rated A - Complies with FCC 47 CFR Part 15.

Lens - High light transmission translucent acrylic.